

SILENT 2 TARGA AND SILENT 2 COMPARISON



SILENT 2
TARGA

Silent 2

The popular **Silent 2** and the new **Silent 2 TARGA** are high-performance light self-launching sailplanes for recreational and sport flying. Both are powered by the proven "Alisport A302efi" engine producing 28hp at 6200rpm. This single-lever FADEC engine has electronic ignition, fuel-injection, electric start, and flywheel generator. The patented counterweighted monoblade carbon-fiber propeller has a swept diameter of 1.4m and electrically retracts into the fuselage along with the engine pylon. The wings of the Silent 2 and of the Silent 2 TARGA have an elliptical planform and five flap settings to cover the entire speed range. The wing geometry is unique in that it varies non-linearly from the root to the tip, both in overall planform shape and in wing section profile. Creation of these unique wings was possible due to the use of advanced materials technology and new computational simulation methods. The wing structure for both sailplanes includes extensive use of carbon fiber, both in the sandwich skins and in the tapered I-beam wing spar which uses pultruded carbon rods for the spar caps. The flaperons stretch for 11.0m of the full wingspan and their range of motion varies from positive landing L, to +4° for thermalling, to 0°, -4°, and S reflex positions for cruising. The Silent 2 TARGA comes with retractable landing gear as standard equipment. The retract gear is also available as an option on the Silent 2 to replace the fixed gear and fairing. Both sailplanes have steerable tailwheels. The Silent 2 has a fixed horizontal stabilizer and the elevator trim is controlled via a joystick mounted trigger. The TARGA also has conventional elevator control, but the incidence of the variable-position horizontal stabilizer is ingeniously governed by the flaperon setting. The removable winglets differ in their design optimization resulting in a span of 13.0m for the Silent 2 with its curved winglets and a span of 13.3m for the TARGA with its vertical-design winglets. The drag-reduction offered by the TARGA's retractable landing gear, vertical-design winglets, and variable-position horizontal stabilizer, further expand the glide performance at higher airspeeds. For customers who prefer to build their own sailplane, both the pure sailplane and fuel-injected self-launcher versions of the Silent 2 and the Silent 2 TARGA are also available as advanced quick-build kits.

alisport.com

3-VIEW SILENT 2 TARGA

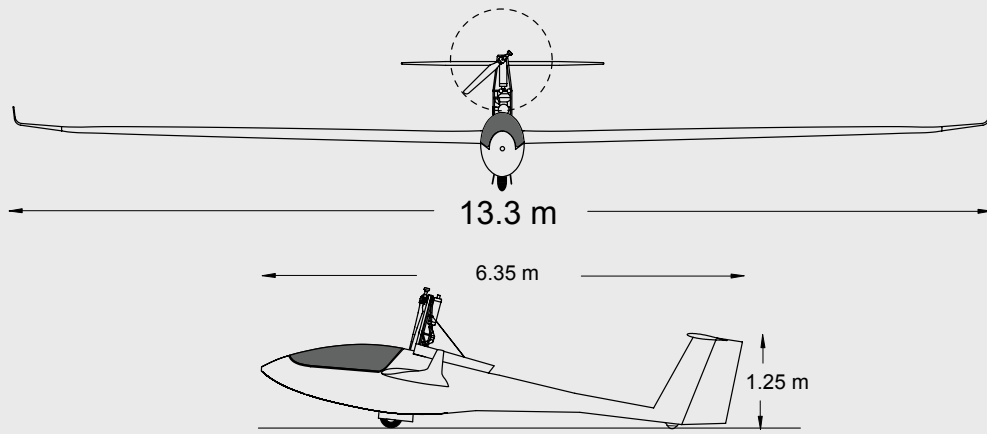

SILENT 2
TARGA

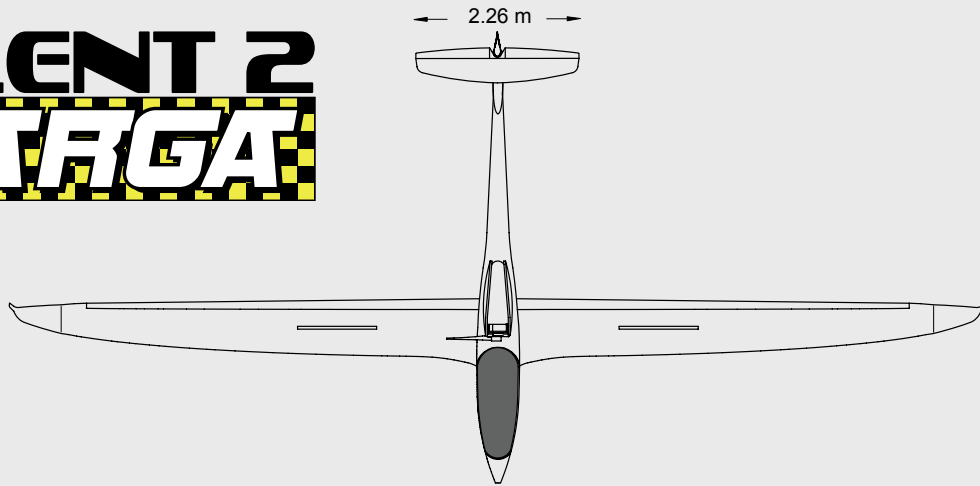

3-VIEW SILENT 2

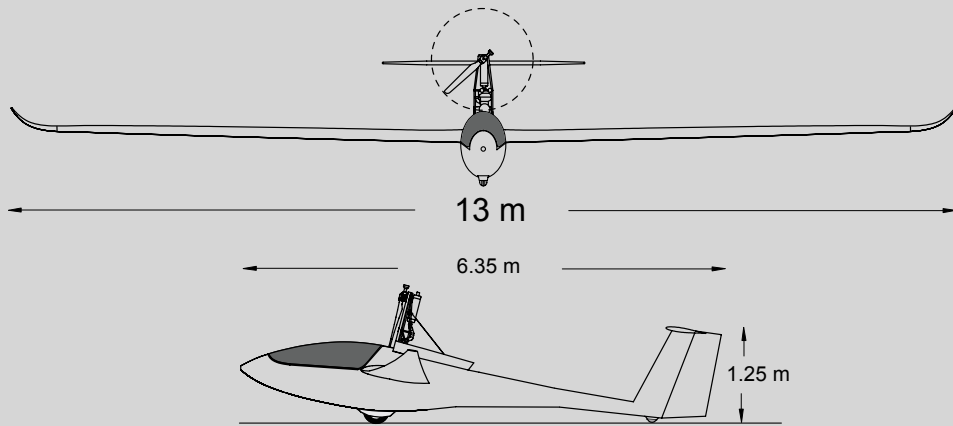

Silent 2

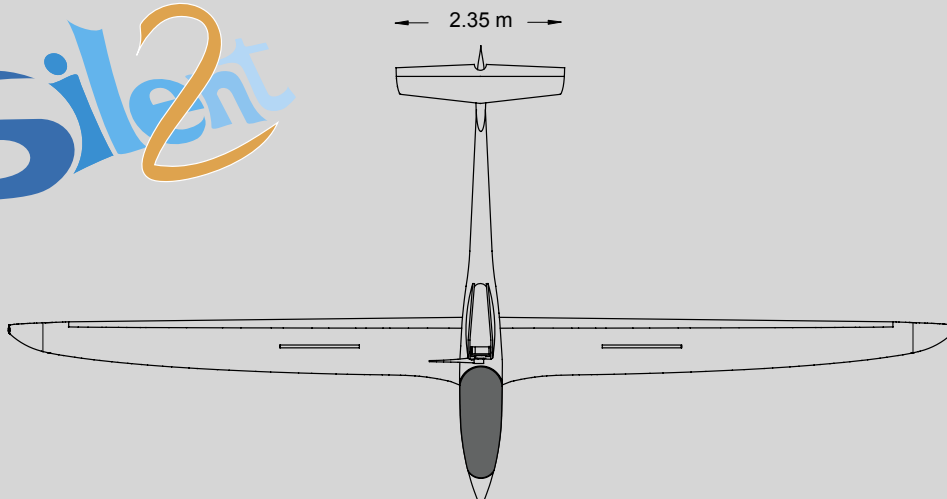

CONFIGURATION COMPARISON:		SILENT 2 TARGA	SILENT 2
	Carbon and glass fiber composite FUSELAGE with epoxy resin.	X	X
	Composite SANDWICH WING SKINS , pultruded carbon spars.	X	X
1	Removable HORIZONTAL STABILIZER with tapered planform.		X
2	Removable HORIZONTAL STABILIZER with elliptical planform.	X	
	Generous 11m FLAPERONS ; 5 flap settings of L +4° 0° -4° S.	X	X
	Fully automatic control CONNECTIONS for airbrakes, flaperons and elevator.	X	X
3	Removable CURVED WINGLETS (wingspan 13.0m).		X
4	Removable VERTICAL-DESIGN WINGLETS (wingspan 13.3m).	X	
	One piece hinged tip-up CANOPY , side window with air vent.	X	X
	Main wheel BRAKE activated via air-brake control aft travel.	X	X
	Joystick-mounted TRIM trigger for elevator trim control.		X
	AUTOMATIC TRIM connected to the flap lever to control the incidence of the variable-position horizontal stabilizer.	X	
	PROPELLER BLADE-STOP control located on the right side of the cockpit.	X	X
	Polymer WING-TIP WHEELS with fairing, for taxiing on asphalt or grass.	X	X
5	FIXED main WHEEL with fairing.		X
6	RETRACTABLE main wheel with hinged doors.	X	
	Steerable TAIL WHEEL with fairing.	X	X
	Nose mounted cockpit VENT and pitot probe.		X
	VENTILATION system with canopy de-fogging.	X	
	In-flight adjustable RUDDER pedals.	X	
	Central INSTRUMENT POD and engine control panel.	X	X
	ENGINE INSTRUMENTS : electric switches, fuse and indicator lights, tachometer, rear-view mirror.	X	X
	BASIC FLIGHT INSTRUMENTS : altimeter 80mm, air-speed indicator 57mm, compass, variometer Winter 57mm, total energy probe (Althaus).	X	X
	RADIO ANTENNA pre-installed in the fuselage.	X	X
	4-point HARNESS with quick-release.	X	X
	Cockpit side POCKET , head rest, seat-pan LINER with CUSHION, TOOL-POUCH .	X	X
	Two-stroke, 28hp, internal combustion ENGINE , with fuel-injection, electronic ignition, electrically retractable into the fuselage. Electric starter, and flywheel generator.	X	X
	AUTOMATIC locking of engine bay doors.	X	X
	Composite mono-blade PROPELLER with patented counter-balance system.	X	X



TECHNICAL DATA**SILENT 2 TARGA****SILENT 2**

Wing span	13.3 m	13.0 m
Length	6.35 m	6.35 m
Height	1.25 m	1.25 m
Aspect ratio	20.0	19.2
Wing area	8.9 m ²	8.8 m ²
Planform	Elliptical	Elliptical
Profile	IMD 050 (16%)	IMD 050 (16%)
Empty weight (without fuel)	185 kg	180 kg
Maximum payload	105 kg	105 kg
Maximum takeoff weight	300 kg	300 kg
Wing load factors	+4.6 g / -2.65 g (at 150 km/h) +4.0 g / -1.5 g (at 220 km/h)	+4.6 g / -2.65 g (at 150 km/h) +4.0 g / -1.5 g (at 220 km/h)
Wing loading	34 kg/m ²	34 kg/m ²
Flaperons	L +4° 0° -4° S	L +4° 0° -4° S
Connections	Fully automatic	Fully automatic
Air brakes	Conventional	Conventional
Fuel capacity	16 liters (reserve 5 l)	17 liters (reserve 5 l)
Fuel consumption at 75 % power	5 l/h	5 l/h

PERFORMANCE**SILENT 2 TARGA****SILENT 2**

Stall speed (Vs)	< 65 km/h (pylon retracted)	< 65 km/h (pylon retracted)
Maneuvering speed (VA)	150 km/h	150 km/h
Maximum speed (VNE)	220 km/h	220 km/h
Maximum L/D	40 at 90 km/h	39 at 90 km/h
Minimum sink rate	0.60 m/s at 85 km/h	0.60 m/s at 85 km/h
Takeoff distance	140 m (on asphalt) 170 m (on grass)	140 m (on asphalt) 170 m (on grass)
Landing distance	100 m	100 m
Climb rate with engine	2.5 m/s	2.5 m/s

“Alisport A302 efi” 28 hp single-cylinder air-cooled engine, with counterbalance shaft, tuned exhaust, FADEC computer controlled mapped fuel-injection and electronic ignition system, electric starter and flywheel generator. Engine extension and retraction operated by electromechanical actuator system.



 **alisport srl**

Via Confalonieri 22 - 23894 Cremella (Lecco) ITALY
tel. +39 039.9212128 - fax +39 039.9212130
www.alisport.com - info@alisport.com